

THIS DRAWING IS UNPUBLISHED. RELEASED FOR PUBLICATION
 © COPYRIGHT BY TYCO ELECTRONICS CORPORATION. ALL RIGHTS RESERVED.

LOC		DIST		REVISIONS			
P	LTR	DESCRIPTION		DATE	DWN	APVD	
FT	0	F1	REVISED PER ECO-08-023607	9/22/08	SS	BC	

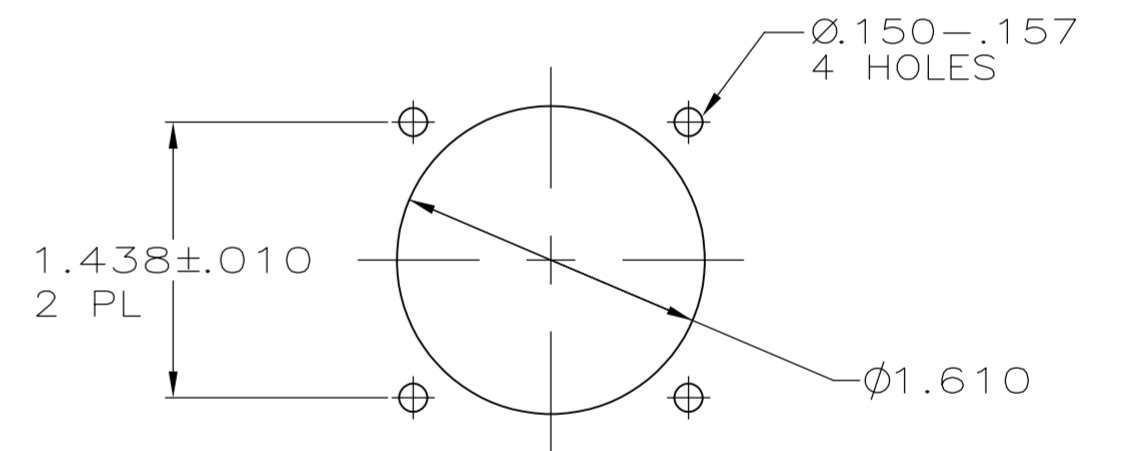
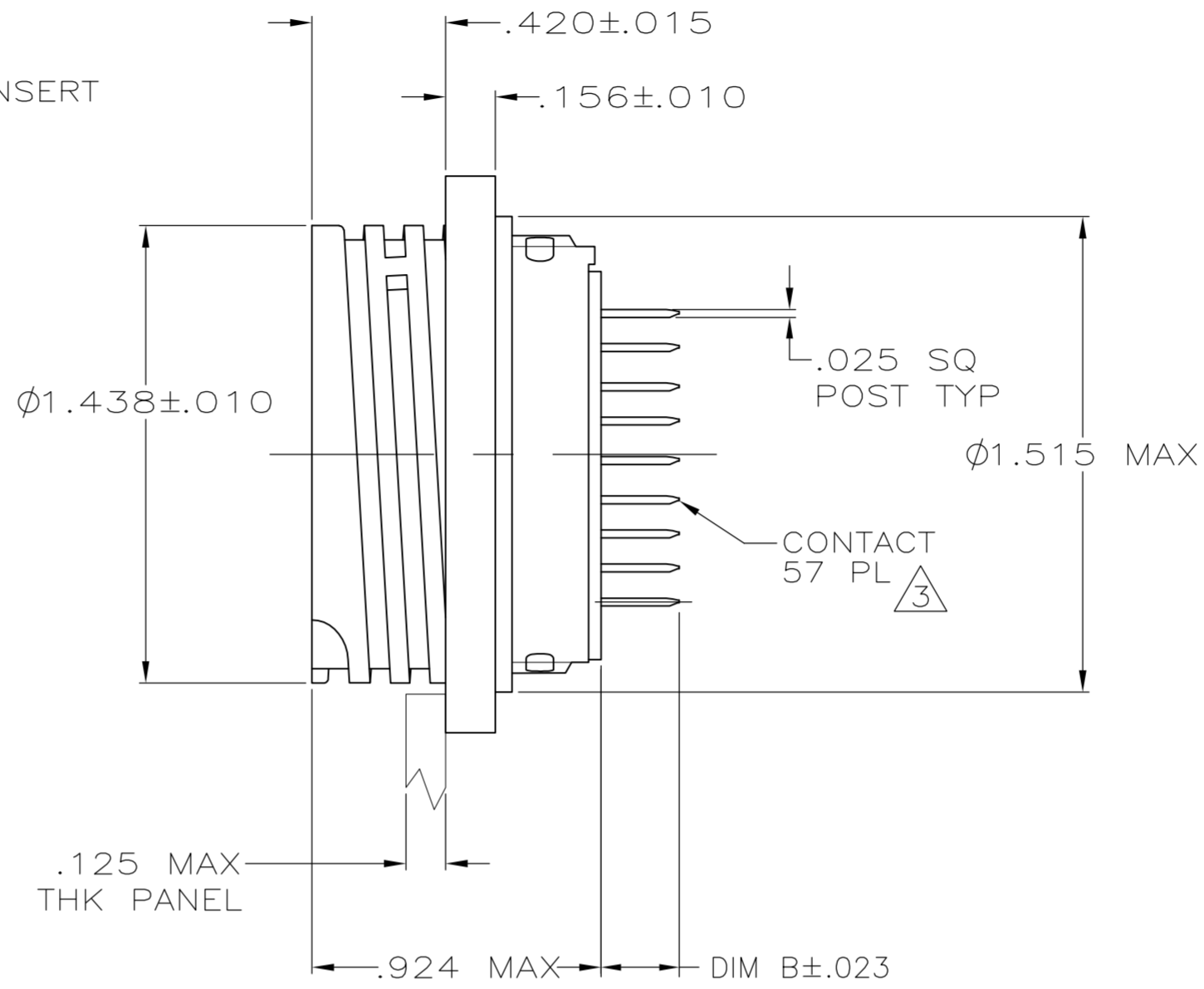
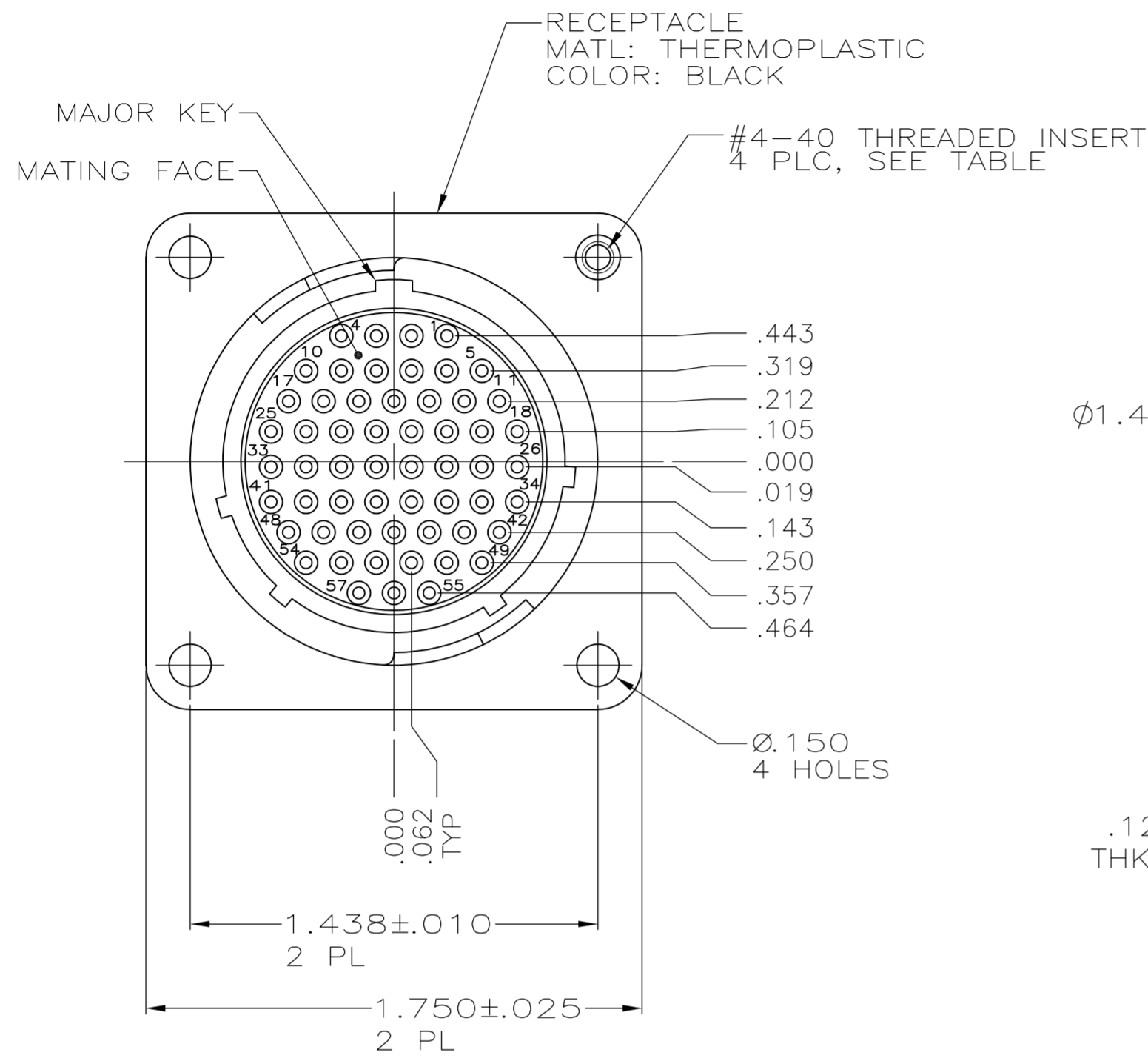

PANEL CUTOUT
SCALE: 1:1

- CONTACT CAVITIES IDENTIFIED BY CHARACTERS ON FRONT AND REAR FACES OF CONNECTOR.
- #4 FASTENER RECOMMENDED FOR MOUNTING.
- △ .000030 MIN GOLD FOR A LENGTH OF .100 MIN FROM MATING END, .000100 MIN TIN-LEAD FOR A LENGTH OF .565 FROM OPPOSITE END, ALL OVER .000050 MIN NICKEL.
- △ .000030 MIN GOLD FOR A LENGTH OF .100 MIN FROM MATING END, .000100 MIN TIN FOR A LENGTH OF .565 FROM OPPOSITE END, ALL OVER .000050 MIN NICKEL.
- △ .000001 MIN GOLD FOR A LENGTH OF .100 MIN FROM MATING END, .000100 MIN TIN ON TAIL LENGTH, ALL OVER .000050 MIN NICKEL.
- RECOMMENDED PC BOARD HOLE SIZE FOR CONTACT POST = .041±.003 DIA.
- △ PRELIMINARY PART NUMBER.

△	.245	△4	NO	1-796329-1
△	.557	△5	NO	796329-5
	.467	△5	NO	796329-4
	.245	△4	YES	796329-3
	.245	△3	YES	796329-2
	.245	△3	NO	796329-1
	DIM B	CONTACT FINISH	4-40 THREADED INSERTS	PART NUMBER

THIS DRAWING IS A CONTROLLED DOCUMENT.		DWN HAMNER 1-31-00	Tyco Electronics Corporation Tyco Electronics Corporation Harrisburg, Pa 17105-3608	
DIMENSIONS: INCHES		CHK M.CHACKO 2-1-00	NAME RECEPTACLE ASSY, POSTED, REV SEX, SIZE 23-57, SERIES 2, CPC	
TOLERANCES UNLESS OTHERWISE SPECIFIED:		APVD M.CHACKO 2-1-00	SIZE A2 CAGE CODE 00779 DRAWING NO C=796329 RESTRICTED TO	
MATERIAL		PRODUCT SPEC	SCALE 2:1 SHEET 1 OF 1 REV F1	
FINISH		APPLICATION SPEC	CUSTOMER DRAWING	
WEIGHT		WEIGHT		